



Alamo Radio Control Society

San Antonio, Texas

FLIGHT SYLLABUS FOR NEW PILOT TRAINING

Contains:

Ground School

Flight Instruction Guideline of Maneuvers

Flying and Safety Tips and Hints

Flight Achievements to Solo

Written and Updated By Buck Murray

Disclaimer

The names Alamo Radio Control Society, Alamo R/C Society, ARCS, etc. shall be synonymous. They shall be all inclusive of all members in good standing, be they club officers, board of directors, instructors or general membership as set forth by the club by-laws.

The ARCS assumes no liability or responsibility in regards to the material herein, or any resulting action thereof. All information was compiled in good faith from printed materials, past experience and general knowledge of the model aviation hobby.

Safety, safe practices and procedures, have been emphasized throughout this manual. Participants are expected to comply with these guidelines at all times as a member of the ARCS.

The ARCS flight assistance program is provided free of charge, by experienced model aircraft pilots who volunteer their time. There are no guarantees as to results. Participants must exercise their own good judgment and common sense in determining their abilities and limitations. The ARCS assumes no liability or responsibility for any action taken, past, present, or future, by any participant in this program.

Participants further attest they are members in good standing with the Academy of Model Aeronautics. Should the possibility of conflict exist with club procedures, guidelines, etc. and A.M.A rules, A.M.A. rules will take precedence.

If you do not find these terms agreeable to your situation, please do not ask to participate in the program.

Ground School

The following section is mainly designed for those who have little or no knowledge of aerodynamics, and/or are totally new to the hobby. Even experienced pilots will benefit from this, as there are some differences between models and full scale. Please read it thoroughly.

First, if you are just starting out: There are benefits to getting an ARF (Almost Ready to Fly) as opposed to kits. Generally speaking, by the time you buy a kit, the hardware and the covering, you have spent as much as the ARF. And it will take you at least twice as long to put the kit together. You will also need the appropriate tools to install the covering. So too with an "Almost Ready to Cover" plane. And if you do destroy an ARF, you won't have the time investment loss. The advantage to the kit is you know how well it is constructed, and the covering will probably be better quality material. Keep in mind that covering the aircraft alone is an art in itself, and will probably take 10 to 15 hours. Build kits in the fall and winter; ARFs in the spring and summer.

Second, if you are just starting out: Don't load up your Visa/MasterCard with all kinds of equipment, flight boxes etc. Get some fuel and get to the field. After you've worked with an instructor, and met some fellow pilots, then decide what equipment you want. There is a lot to choose from. And there is a lot of good used equipment available through the club or swap meets. All too often, new hobbyists overspend, don't learn as quickly as they had hoped, and get discouraged. This is especially true if they tear up their first airplane. Keep your investment small until you gain some momentum.

Third, now that you've started: Unless you're sure of yourself, don't be too quick to buy that "second" plane. Chances are you may be buying a second "first" plane. Take your time. On the other hand, you may surprise yourself and be able to jump directly to a "third" or "fourth" plane. Get some flight time in after you've soled and you'll have a better idea.

We will not get into any discussions of model kit building, or radio systems at this time. Together they could have their own entire manual.

Granted, one doesn't have to know how to fly the space shuttle to fly a model aircraft. However, a general understanding of basic aerodynamics will help to understand why it does what it does. Our objective here is to provide you with the concept of aerodynamics, not the technicalities. For those who wish to go into aerodynamics at greater depth, student or private pilot flight manuals are a good place to start.

Note: Referring to aircraft as to right or left, is as a pilot would view it from the cockpit.

Wings:

There are three basic wing profiles.

Flat Bottom:

Creates the most lift and is the most stable. Most trainers are flat bottom.

Semi-Symmetrical:

Still stable, yet allows more maneuverability and extends aerobatic capability. Great for "second" planes.

Fully Symmetrical:

Least stable and most aerobatic. For more experienced flyers only. There are three basic wing locations.

High-Wing, Mid-Wing, Low-Wing:

Stability diminishes as the wing comes down; the high wing being the most stable. Here too, most trainers are high wing. A fully symmetrical, mid-wing with no dihedral is the most aerobatic.

Dihedral:

Dihedral is the angle in the wing when looking at it from front or rear. The more dihedral, the more stable and self recovering. The straighter, the more aerobatic but less stable. A low-wing aircraft requires more dihedral to be as stable as a high-wing, all other factors being equal.

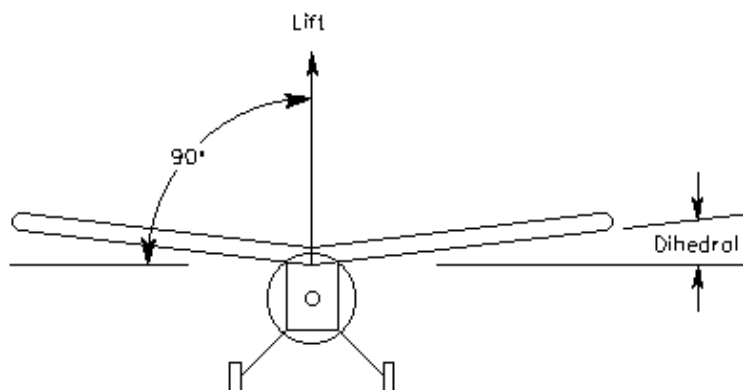

Washout: Washout is a twisting of the wing when viewed from the wing tip. The trailing edge is higher at the wing tip than at the fuselage. This increases stability and self-recovery. It allows the outer wing area to still "fly" (maintain control) even if the inner wing area is in a stall condition. Refer to "stalls" later. Wash-in is reverse, and has no practical application.

Ailerons: Ailerons control the bank of the aircraft which turns the aircraft. Refer to "lift" later. The up aileron decreases "lift", while the down aileron creates more "lift", thereby banking the aircraft. The aircraft always banks or turns toward the up aileron.

Vertical Stabilizer: The stationary part of the rudder assembly.

Rudder: The movable control surface of the assembly. Its primary function is to coordinate the bank and turn. However, in the case of model aircraft, it can be used to steer or turn the craft.

Horizontal Stabilizer: The stationary part of the elevator assembly.

Elevator: The movable control surface of the assembly. Its primary function is to control the angle (nose up, etc) of the aircraft. However, in the case of model aircraft, it is basically used to control altitude. Technically, power controls altitude and elevator controls angle, which in turn controls airspeed. Refer to more advanced flight manuals.

Flaps: Flaps create more "lift". There are several basic types of flaps, none of which are used on trainer planes. Refer to more technical manuals.

Lift: Lift is created when the air moving over the top of the wing moves faster than the air underneath. Air over the top must travel a greater distance; therefore it must move faster to get to the rear at the same time. The faster the air moves past a surface, the less pressure it exerts on that surface. The pressure underneath is greater pushing the wing up. This is lift. Lift is always 90 degrees to the relative wind. Lift is always 90 degrees to the span of the wing.

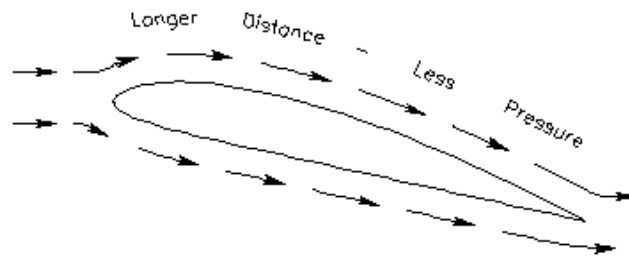

Relative Wind: RW is the air coming at the aircraft; it is always exactly opposite the direction of travel. Do not confuse this with the wind conditions you are flying in. The angle of the wing as it hits the RW is called the angle of attack. Too high of an angle of attack, without enough airspeed, will cause the wing to stall. Refer to "stalls" later.

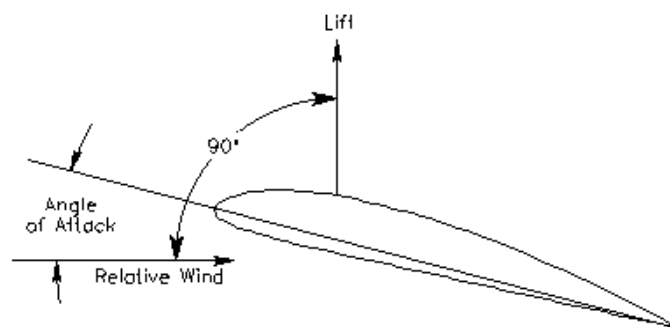

Components of lift: When the aircraft is banked, the "lift" is banked too. The "vertical component of lift" is no longer as great. This is why you have to add up elevator to maintain altitude. The "horizontal component of lift" causes the aircraft to turn. If you bank too steep, the "vertical component" will lessen even more and the wing will stall and fall. Refer to "stalls" later.

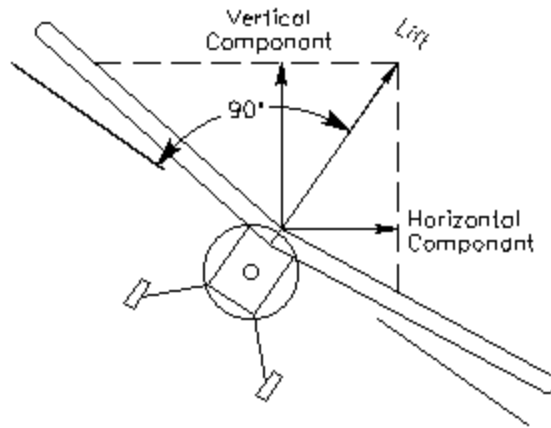

Propellers: A propeller is nothing more than a rotating airfoil in the horizontal direction. Applying more power creates more horizontal lift (better known as thrust) which pulls the aircraft through the air. Do not think of a propeller as blowing air rearward.

P-Factor: For the sake of simplicity we will only say that P-factor is the unequal thrust or torque of the propeller. During power on, or climbing conditions, the right side of the propeller produces more thrust. This causes the aircraft to drift left. This is why an aircraft that rolls straight will run off to the left of the runway on take-off. Correct with a slight right rudder.

Stalls: A stall is the loss of "lift". This condition occurs when the angle of attack becomes too great for the air to flow smoothly over the top surface. The air then becomes turbulent (much like the spoiler on a race car) and no longer produces lift. When this happens, the nose of the aircraft will drop abruptly resulting in the loss of altitude. Stalls can occur with power on, or power off, at low speed or high speed, depending on various other conditions. The most common are while climbing too steeply and turning after take-off, or when banking too steeply while turning final to land. All stalls have one thing in common. They all require lowering the nose to recover. Point of interest: A spin is nothing more than a sustained stall with rotation.

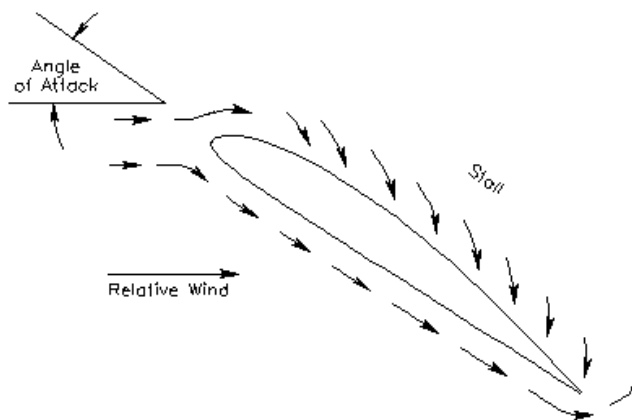

Flight Pattern:

The FP, or traffic pattern, is made up of four legs. Starting at the runway, the first 90 degree turn is the crosswind leg. The second 90 degree turn becomes the downwind leg which is parallel to the runway. The third turn is the base leg which is 90 degrees to the runway again. The fourth turn becomes the final leg towards the runway. Henceforth the term: "Turning final". Proper departure for the pattern is to turn only 45 degrees not depart straight out the crosswind leg. Proper approach and entry is to head in on a 45 degree angle towards the downwind leg. Aim for the end of the runway where you plan to set down. Turn downwind when you are at an appropriate distance away from the runway. Do not enter the pattern straight in on the downwind as you may encounter departing aircraft. Note: The below diagram is not the ARCS field but an example of a typical flight pattern.

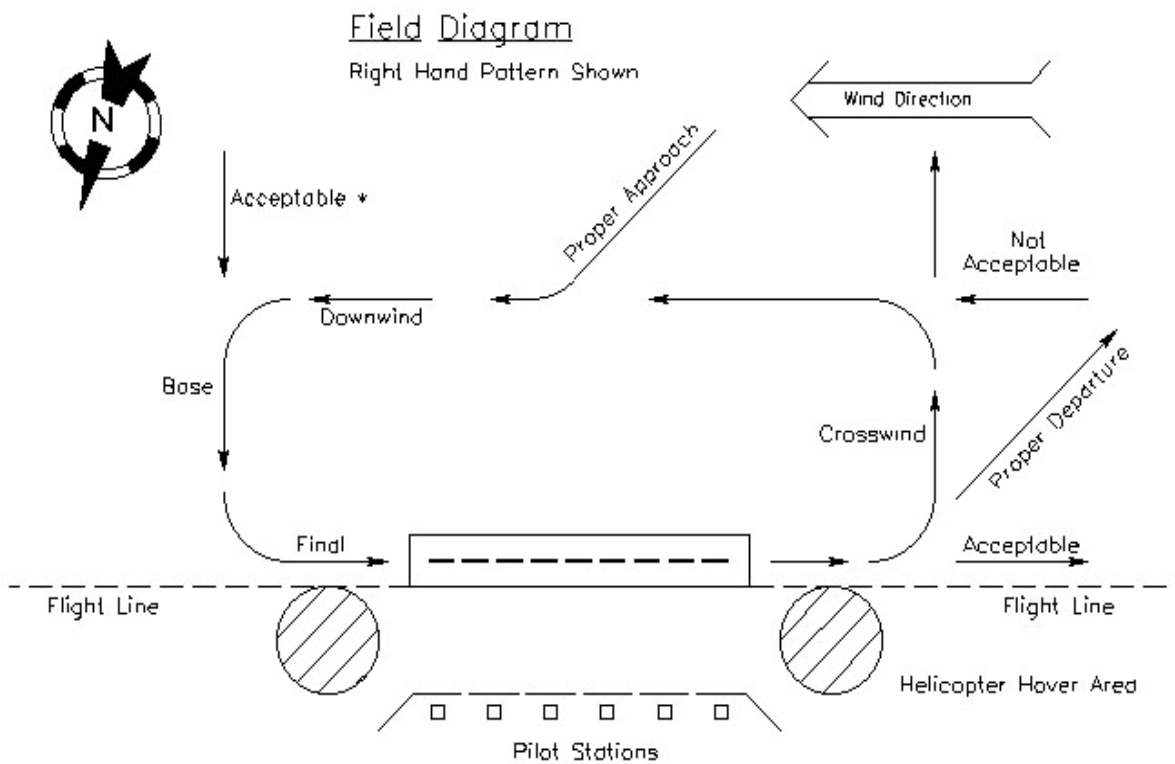

There are those who believe that flying a model aircraft is more difficult than a full scale. Visualizing yourself from the aircraft view takes some practice. It's like an out of cockpit experience. Everything is fine so long as you are coming towards yourself, is a whole different story. Think of it as sitting backwards on the dashboard of your car steering wheel between your legs, and driving down the road. Here's a reference list to help you along.

Aircraft Direction	
Control Movement	Aircraft Reaction
Aircraft Going Away	
Aileron	Same
Elevator	Same
Rudder	Same
Coming Towards You	
Aileron	Reversed
Elevator	Same
Rudder	Reversed
Inverted Going Away	
Aileron	Same
Elevator	Reversed
Rudder	Reversed
Inverted Coming Towards You	
Aileron	Reversed
Elevator	Reversed
Rudder	Same

Flight Instruction Guideline of Maneuvers

This section is not intended to teach you the mechanics of flying an aircraft. That is left to the trainers. Rather, its purpose is to give you an overview of what to expect, what you should know, and the sequence to learn.

It is expected that all student pilots fly with more than one trainer. Each individual trainer has their own methods and techniques. What works for one, may not work for another. It is wise to get exposure to several and decide for yourself. Remember however, the basics of aerodynamics never change.

Most students can expect to fly 2 or 3, 10 to 15 minute flights each time out. Most can expect to have 5 or 6 of these sessions before earning their "wings". Don't get discouraged. Some students struggle along until one day everything just clicks, and then it's: "Hey look, I'm doing it!"

Familiarize yourself with the transmitter. Practice at home. You should be as familiar with it as you are with the location of the controls of your car, or a ten-speed bike.

Likewise, before any flight instruction, familiarize yourself with the Field Procedures as described in the New Member Booklet and "Flying and Safety Tips" in this manual. Make safety your number one priority.

Here's an exercise any combination of pilots can try. It works best with a trainer and two students. One student holds the aircraft while the trainer works with the other student and the transmitter. As the student on the TX works the controls, the student holding the plane maneuvers it. This is great for "coming at you orientation". And if he doesn't level out those ailerons, just keep rolling until inverted. This saves a lot of aircraft from needless repairs! Try it, it works. And don't forget to hang up a frequency pin while doing this exercise.

Note: There are computer model aircraft flight simulators available. They may, or may not help you in the leading process. The general opinion still remains that there is nothing like actual "stick" time. Simulators are probably better suited to help you experiment with more advanced maneuvers after you've soloed.

Basics of Pre-Flight: Refer to "Aircraft Check Out Guideline"

- Check receiver battery
- Fill fuel tank to full
- Frequency tag on board
- Transmitter on
- Receiver on
- Check controls
- Start engine
- Range check
- Check engine vertical running
- Check engine idle and shut off
- Carry aircraft to pilot station line
- Full extend transmitter antenna*
- Final check controls

*Optional: For those using the buddy box system; student may pull buddy box antenna part way out to get in the habit. Note: Buddy box power is always "off". Never turn buddy box power "on" unless your system requires it!

Post Flight Shut-Down:

- Taxi to pilot station
- Shut off engine
- Turn off receiver
- Turn off transmitter
- Carry back to pit area
- Reset any controls as necessary
- Transmitter off again
- Remove frequency tag from board**

**Suggestion: Place your frequency tag somewhere you have to move it again to go flying. Hang it over transmitter, engine, wing etc. Your back pocket or in the flight box is not a good location. In your haste to fly with an available trainer, you will probably forget to hang it on the board.

The time has come to start putting this all together.

Ground Taxi: Student may practice on their own. Suggest developing skills with wing off. Especially practice "coming at you" orientation. Practice running up and down the runway at higher speed. Suggest moving aileron stick at same time to develop association.

Straight & Level Flight: Trainer will take off and trim the aircraft. He will hand off to you to teach you simple elevator and aileron usage. He will re-trim aircraft as necessary.

Turns: Apply up elevator to maintain altitude. Do not exceed 30 degrees of bank. Coordinate with slight rudder. Get comfortable just driving around in the sky.

Oval (Racetrack) Patterns: Practice a combination of previously learned skills. Develop consistency by repeating pattern. Practice both left and right.

Figure 8 Patterns: Practice maintaining altitude while developing left to right, and right to left transition and coordinate.

Rudder Only Turns: Develop ability to pilot aircraft should ailerons ever fail. Practice previously learned maneuvers.

Slow Flight: Practice previous maneuvers at reduced speeds. Learn how to re-trim the aircraft. Learn how power settings affect altitude and elevator controls.

Approach & Go-Around: Learn the flight pattern. Practice low flight line fly-bys. Left and right hand patterns required.

Stalls: Learn the proper recovery from power off, power on, turning stalls. Learn to recognize the situation before it happens.

Take-Offs: For the first several take-offs, the student may stand behind the aircraft at the end of the runway. Straight out departure until gaining sufficient altitude before turning. Practice trimming the aircraft after climbing to a safe altitude.

Simple Aerobatics: Exposure to loops and inverted flight by the trainer. Student will help develop his own confidence while learning recovery techniques.

Unusual Attitudes: (Not to be confused with a weird sense of humor) Experience with recovery from inverted flight, spins etc. Trainer may demonstrate. Student should be able to recover from an inverted situation.

Landings: Practice proper entry into the pattern and develop judgment skills; power vs. altitude. Left and right patterns required. Trainer may demonstrate simulated dead stick from a distance out. Be careful not to bank too steep in the pattern at low speed, especially from base leg to final.

Advanced Aerobatics: Optional, but recommended. Learn aileron rolls, barrel rolls, sustained inverted flight, immelman turns, and Cuban eights. For the brave; split-S and spins. You've already learned some of this recovering from inverted. Develop better coordination skills and build your confidence.

Turbulence Flying: The day will come when you say to yourself: "I shouldn't be up here!" That thought usually occurs soon after you've soloed, just after pattern departure, and you suddenly realize you're already over the canal. Don't panic. Keep your cool. Although not required, it is a good experience to go up with a trainer on a turbulent day. Scary as it is, it teaches you how to stay on top of a situation where the aircraft is almost out of control. A windy day can blow you too far away for orientation, or turn you inverted in a heartbeat. Keep you bank shallow on windy days. Landings require partial power on, especially crosswind.

By now you should be driving around in the sky by yourself, and loving every minute of it. You should be proud of your accomplishments. Please check out the following section on Flying & Safety-tips & Hints if you haven't done so already. You will find it very helpful.

Flying Safety Tips and Hints For the Beginner and Novice Pilot

- Roll test steering in a driveway or basement. If it doesn't roll straight at home, it won't roll straight on a runway. Set control to the least sensitive position.
- Put Monokote (or otherwise) small marks at the C.G. (Center of gravity) on the wing to indicate balance location. Makes it easy to check at field.
- Balancing laterally (side to side) will help aircraft track better in maneuvers. Hold at spinner and tail. Add wing tip weight as necessary.
- Check receiver battery every 2-3 flights. Make a chart of how long you have flown vs. Voltage drop. Do not operate below 4.9 volts.
- Always turn on transmitter 1st, receiver 2nd. Always turn off receiver 1st, transmitter 2nd.
- Range check your system before 1st flight every time out. This should be performed with engine running at both idle and full throttle.
- When using the buddy box system, make sure both boxes are identical. Never turn buddy box power "on"!
- Remove transmitter neck straps when starting engines.
- If you don't have a starter, at least use a "chicken stick". Do not hit it against the propeller; start your flip with the stick next to it. (Touching)
- Never jamb a running starter onto the spinner. Back up the propeller, and place the starter cone against spinner before turning on.
- When you start your engine, look at your watch and keep track of time. After flight, check fuel level to judge maximum available flight time.
- Do not reach over propeller to adjust needle valve. Do it from the rear. Do not position yourself (or others) to the side of a rotating blade. It could fail on run-up or kick up debris.
- Taxi while holding "up elevator" on tricycle gear aircraft.
- Fly with a copilot/spotter.
- Never practice maneuvers at low altitude. Fly 2-3 mistakes above the ground.
- When trimming an aircraft in flight, trim only until it stops the incorrect movement. Trying to correct entirely will only put it out of trim to the opposite direction.
- Most trainer aircraft will recover from unusual attitudes (mistakes) by killing the power and pulling up elevator (depending on altitude). Be ready to level out and apply power.
- Remember, unless you are "dead stick", you do not have to land. If it's not right, go around. It's much easier, and safer, to do it over rather than try to salvage a bad approach.
- If you get nervous for any reason, climb out and do some horizontal figure eights over the field. When you calm down, try again. Don't push yourself to try again too soon. Take your time.
- Do not fly too far away as it is easy to get disoriented. This is especially true when the sun is low on the horizon and the aircraft becomes a silhouette.
- If you are using dual rates, return to high rate before entering the landing pattern. Do a couple of turns to adapt to the greater sensitivity again.
- On flat bottom wing trainer planes: Low speed handling (banking characteristics can be improved by raising each aileron an 1/8" or so. It makes the "up" aileron more effective.

- Installing larger (2 3/4", 3") wheels on your trainer will:
 - 1) Make taxiing in grass easier.
 - 2) Improve your visual orientation in the air.
 - 3) Improve your landings as gear won't bend as easily.
- Maintain your flight path. Do not make any erratic maneuvers to avoid faster, more maneuverable overtaking aircraft (experienced pilots etc.). It is their responsibility to avoid you. However, make a conscientious effort to not be a hazard either.
- If it is obvious that you are going to crash, kill the power to minimize damage.
- If for any reason an aircraft is in trouble and headed for the pit area or spectators: Do your level best to kill the power and ditch it. Don't try to save it. Planes are cheaper than people. It's a small sacrifice to make.
- If your aircraft does go down in the field or trees-Don't move! Note where you are standing, and pick a far distance reference point or object. Follow a straight line in your search and rescue effort.
- If you are searching in the trees, listen to aircraft overhead to orient yourself to the flight line and runway. It's a jungle out there.
- When you do recover a crashed aircraft, be sure to pick up every last part, piece and splinter. You'll be glad you did when you decide to rebuild it after the shock wears off. All those little pieces can be glued together to make templates to create replacement parts.
- After each flight, immediately reset the elevator trim to the "full fuel tank" position. Otherwise you probably won't remember until you are about 10 feet off the ground on the next take-off. (And headed back down to mother earth!)

Even long after you've soloed, don't be afraid to ask for additional help or instruction. That's what we're here for.

"Wings"

Flight Achievements to Solo

Name: _____ **A.M.A. number:** _____

Maneuver	Date	Trainer Name
L&R Oval Patterns	___/___/___	_____
Figure 8 Patterns	___/___/___	_____
L&R Approach and Go-Around	___/___/___	_____
Loops	___/___/___	_____
Recovery From Inverted	___/___/___	_____
Right Take-off & Right Hand Pattern	___/___/___	_____
Right Take-Off & Right Hand Pattern	___/___/___	_____
Right Landing & Right Hand Pattern	___/___/___	_____
Right Landing & Right Hand Pattern	___/___/___	_____
Left Take-Off & Left Hand Pattern	___/___/___	_____
Left Take-Off & Left Hand Pattern	___/___/___	_____
Left Landing & Left Hand Pattern	___/___/___	_____
Left Landing & Left Hand Pattern	___/___/___	_____

Solo Date: _____ **Instructor:** _____